

Smart Structures

Lecture Outline

- Definitions
- Need for Smart Structures
- Applications
- Current Needs & Research Programs
- Components of a Smart Structure

Smart Structures

Concept Definition

- Integration of functions
 - sensor, actuator and control mechanisms

The concept of a smart structure can be described as a "system which has intrinsic sensor, actuator and control mechanisms whereby it is capable of sensing a stimulus, responding to it, and reverting to its original state after the stimulus is removed."

Smart Structures

Concept Definition

- Stimulus
 - stress, strain, light, electric field, gas molecules, temperature and pressure, etc.

The concept of a smart structure can be described as a "system which has intrinsic sensor, actuator and control mechanisms whereby it is capable of sensing a stimulus, responding to it, and reverting to its original state after the stimulus is removed."

Smart Structures

Concept Definition

- Response
 - motion or change in optical properties, modulus, surface tension, piezoelectricity or pyroelectricity, etc.

The concept of a smart structure can be described as a "system which has intrinsic sensor, actuator and control mechanisms whereby it is capable of sensing a stimulus, responding to it, and reverting to its original state after the stimulus is removed."

Smart Structures

Concept Definition

The concept of a smart structure can be described as a "system which has intrinsic sensor, actuator and control mechanisms whereby it is capable of sensing a stimulus, responding to it, and reverting to its original state after the stimulus is removed."

Smart Structures

Concept Definition

- Integration of functions
 - sensor, actuator and control mechanisms
- Stimulus
 - stress, strain, light, electric field, gas molecules, temperature and pressure, etc.
- Response
 - motion or change in optical properties, modulus, surface tension, piezoelectricity or pyroelectricity, etc.

The concept of a smart structure can be described as a "system which has intrinsic sensor, actuator and control mechanisms whereby it is capable of sensing a stimulus, responding to it, and reverting to its original state after the stimulus is removed."

Smart Structures

Definition of Smart Structures

- Smart Material
 - Material which has the intrinsic or extrinsic capabilities to respond to an external stimulus in a functionally useful manner
 - ZnO varistors are used as protection against high voltage breakdown in power lines. When struck by lightning, the electrical resistance of these varistors decreases and current is passed to ground. Once the high voltage is removed, the resistance properties are restored.

Smart Structures

Definition of Smart Structures

- Smart Structure
 - A smart structures integrates the properties of embedded sensors, actuators and control mechanisms in order to respond to a given stimulus in a functionally useful manner. Usually this involves implementing hardware and/or software control mechanisms.

Smart Structures

Need for Smart Structures

- Optimizing response of large, complex systems
 - adaptive response will cope with unforeseen circumstances
 - enhance the range of survivability conditions
 - early warning systems

Smart Structures

Need for Smart Structures

- Perform enhancements otherwise not possible
 - minimizing a satellite antenna's surface distortion - increase precision
 - control of pointing accuracy under thermal or other disturbances

Smart Structures

Need for Smart Structures

- Functionality
 - light weight
 - preventative maintenance
 - performance optimization

Smart Structures

Need for Smart Structures

- Optimizing response of large, complex systems
 - adaptive response will cope with unforeseen circumstances
 - enhance the range of survivability conditions
 - early warning systems
- Perform enhancements otherwise not possible
 - minimizing a satellite antenna's surface distortion - increase precision
 - control of pointing accuracy under thermal or other disturbances
- Functionality
 - light weight
 - preventative maintenance
 - performance optimization

Smart Structures

Smart Structure Classifications

- Passively Smart
 - Structures have the ability to respond to a stimulus in a useful manner, without assistance of electronic controls or feedback systems

Smart Structures

Smart Structure Classifications

- Actively Smart
 - Structures utilize feedback loops which accelerate the recognition and response process

Smart Structures

Smart Structure Classifications

- Very Smart (or Intelligent)
 - Structures utilize the nonlinear properties of the sensor, actuator, memory and/or feedback systems to *tune* the response behaviour

Smart Structures

Smart Structure Classifications

- Passively Smart
 - Structures have the ability to respond to a stimulus in a useful manner, without assistance of electronic controls or feedback systems
- Actively Smart
 - Structures utilize feedback loops which accelerate the recognition and response process
- Very Smart (or Intelligent)
 - Structures utilize the nonlinear properties of the sensor, actuator, memory and/or feedback systems to *tune* the response behaviour

Smart Structures

Smart Structure Applications

- Aerospace
 - Damage detection
 - Vibration control
 - Shape control
 - Adaptive structures
- Defence
 - Firing accuracy of weapons
 - Vibration and noise reduction in submarines
 - Adaptive wings for aircraft and missiles

Smart Structures

Smart Structure Applications

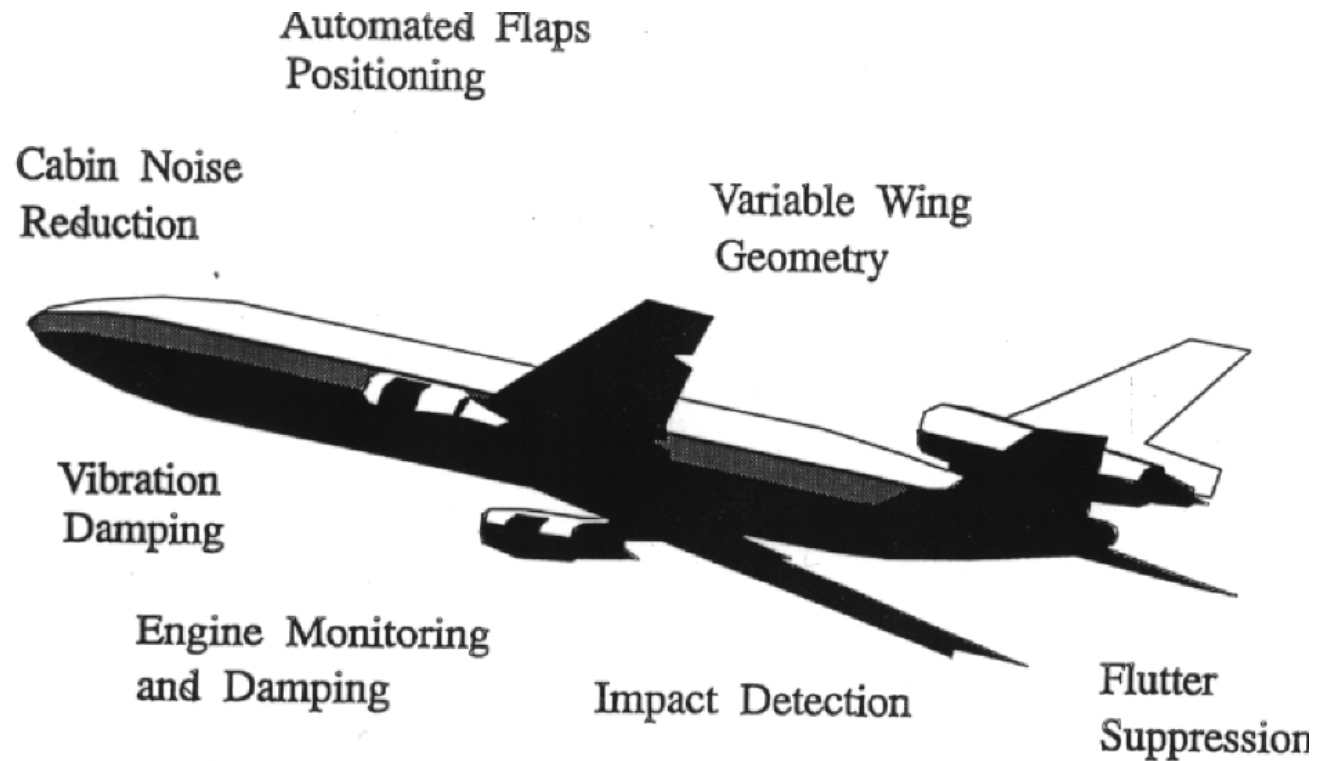

Smart systems envisaged for application in aircraft.

Sensor Technology Limited

Smart Structures

Smart Structure Applications

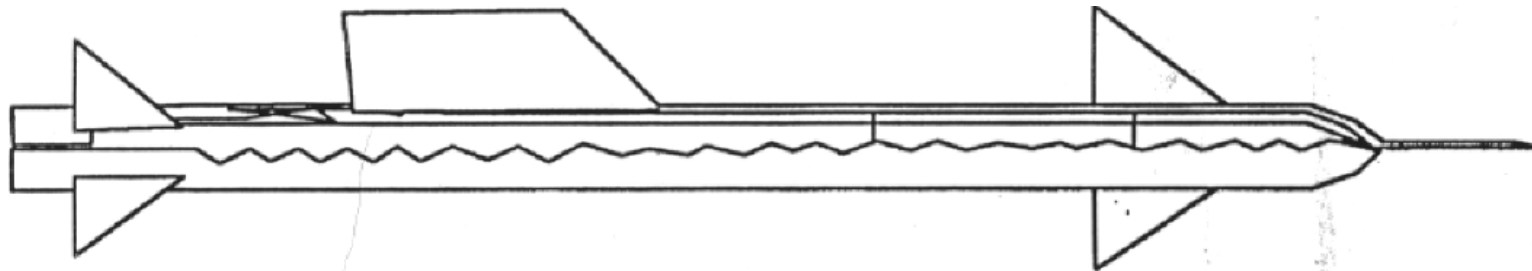

"Smart" fin
material warps to
improve maneuver

Smart missile
with rigid fins

Rather than use rotating fins to produce maneuvers, rigid fins constructed of "smart" materials will warp to appropriate shape

Smart Piezo Materials for "Stealth" Technology

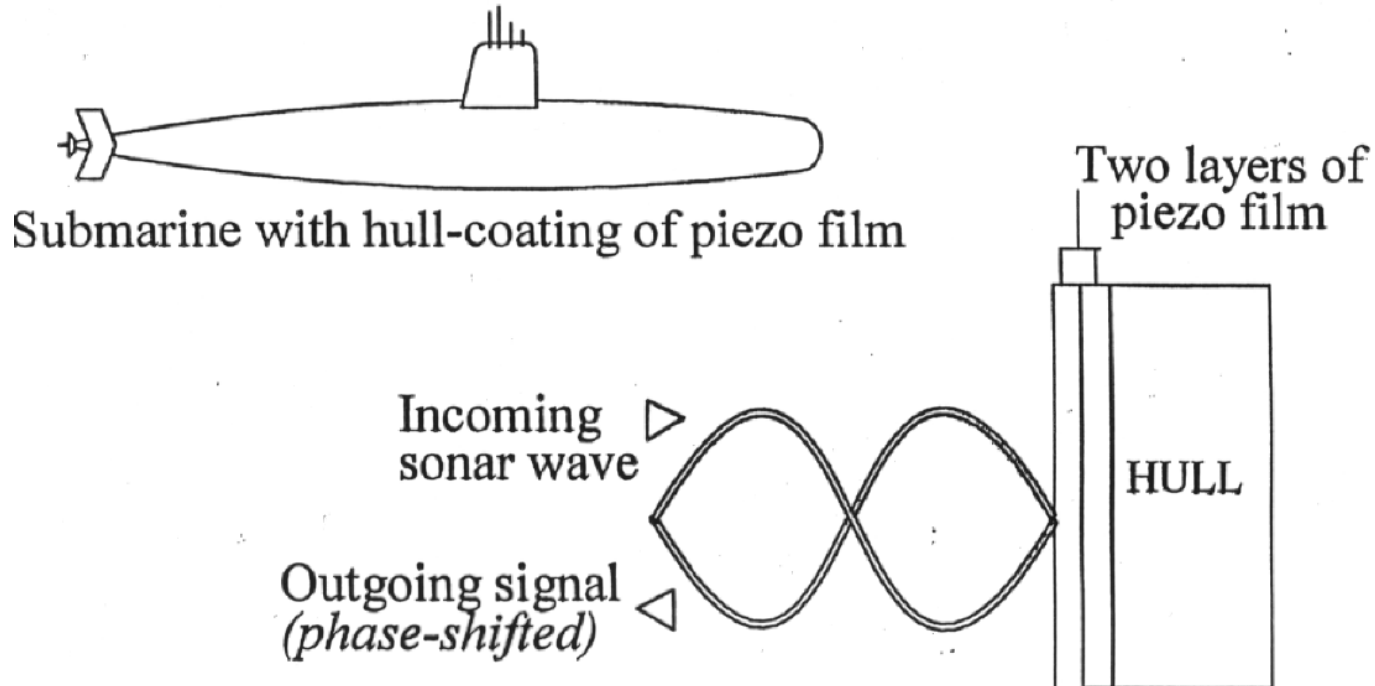

Smart Structures

Smart Structure Applications

Acoustic Boundary Control Tiles for Underwater Structures

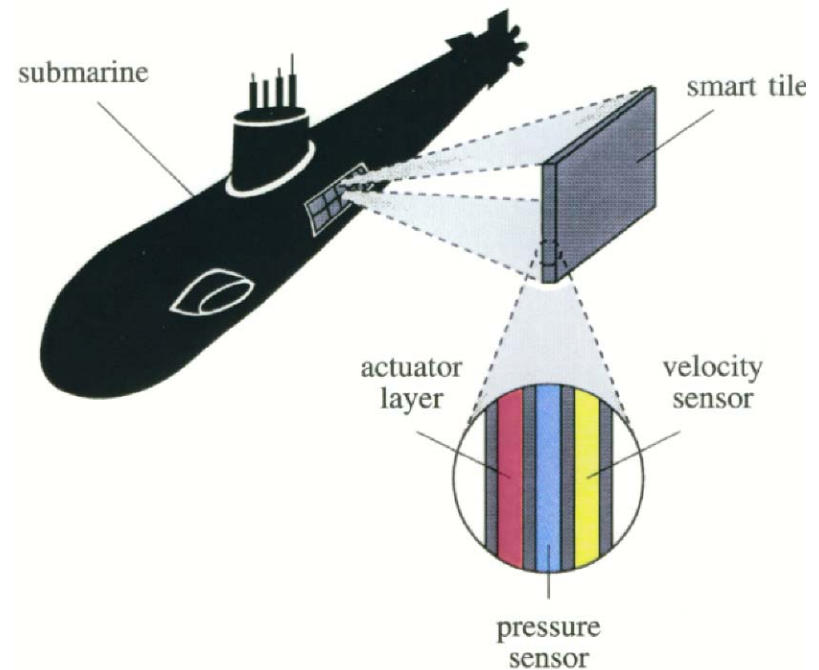

Smart Tile Dimensions

25 cm wide
25 cm long
4 cm thick

Smart Structures

Smart Structure Applications

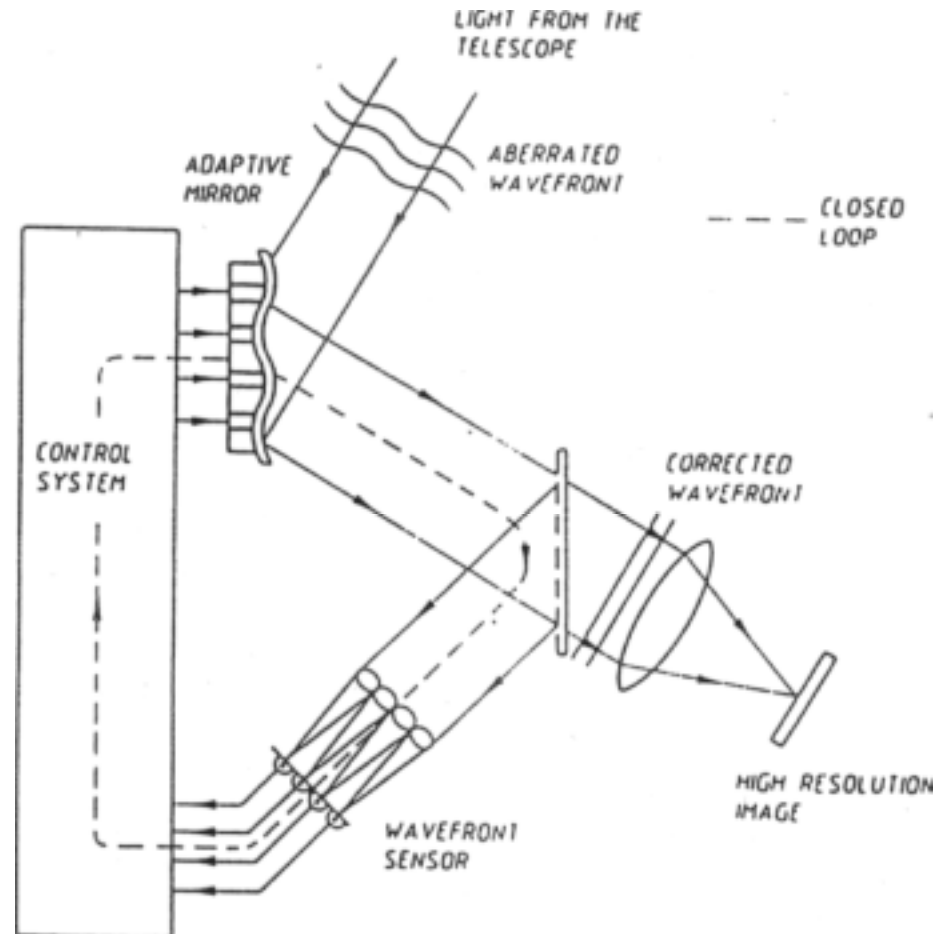

Sensor Technology Limited

Smart Structures

Smart Structure Applications

Smart Barrel-Stave Flextensional Projector

Conceptual Projector

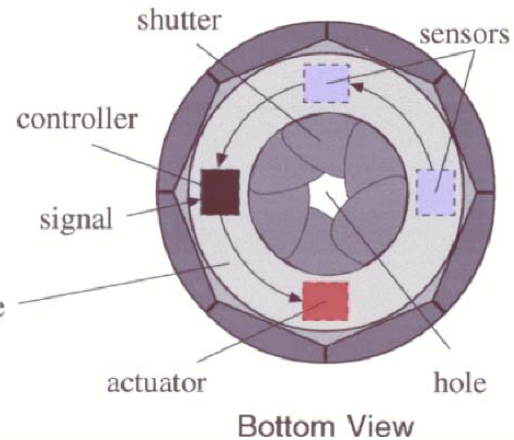
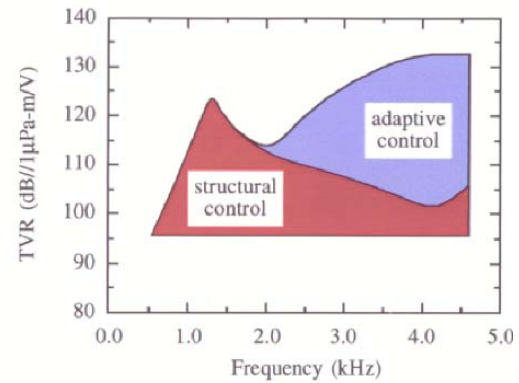
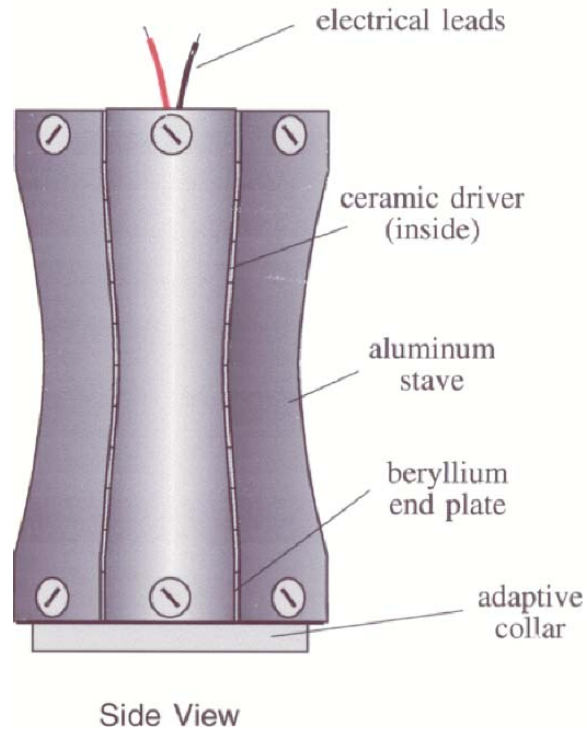

Smart Structures

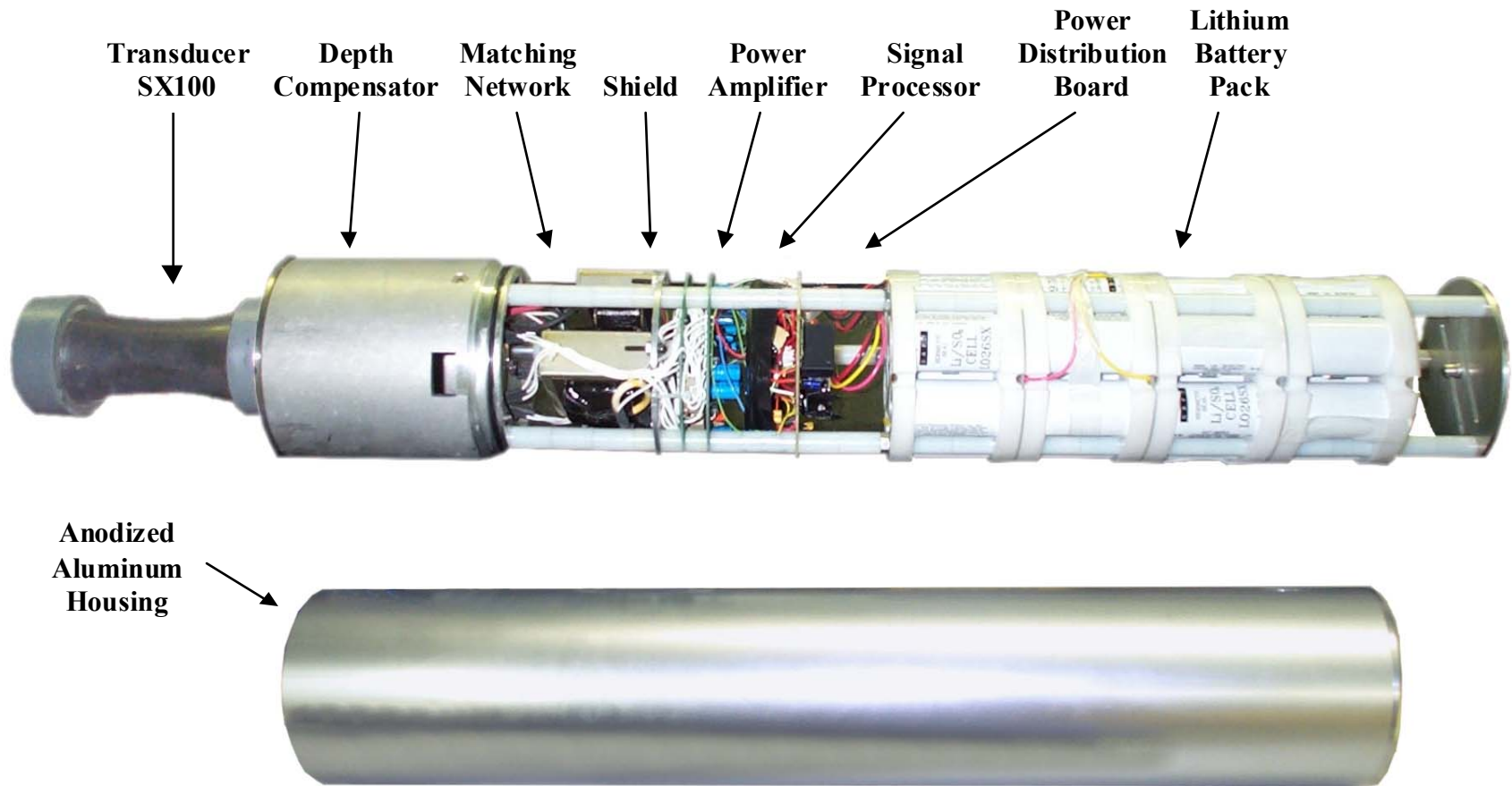

Smart Structure Applications

Sensor Technology Limited

Smart Structures

Smart Structure Applications

- Automotive
 - Passenger comfort (noise control in cabin)
 - Vibration control (active engine mounts)
 - Health monitoring (smart sensors)
- Industrial
 - manufacturing (machine tool chatter control)
 - Air conditioning and ventilation (noise control)
 - Mining machinery (vibration control)

Smart Structures

Smart Structure Applications

Smart Automobile

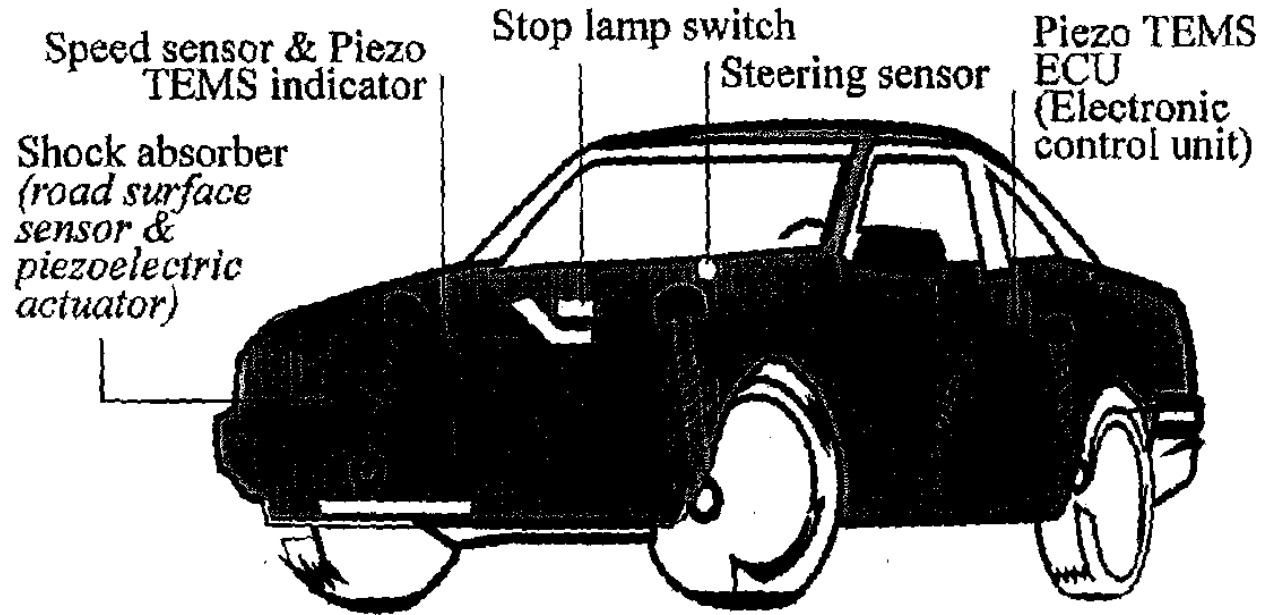

Smart Structures

Smart Structure Applications

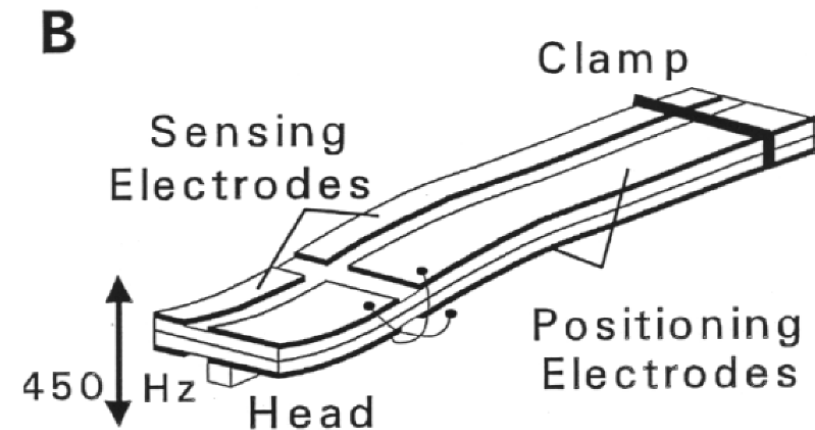
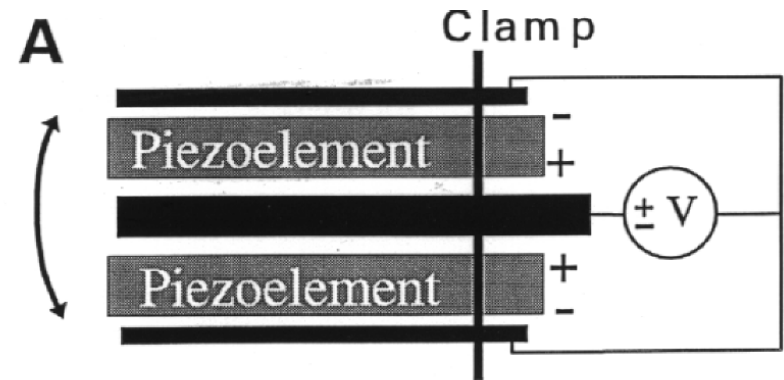

Schematic of a ceramic actuator assembly used for micropositioning

Smart Structures

Smart Structure Applications

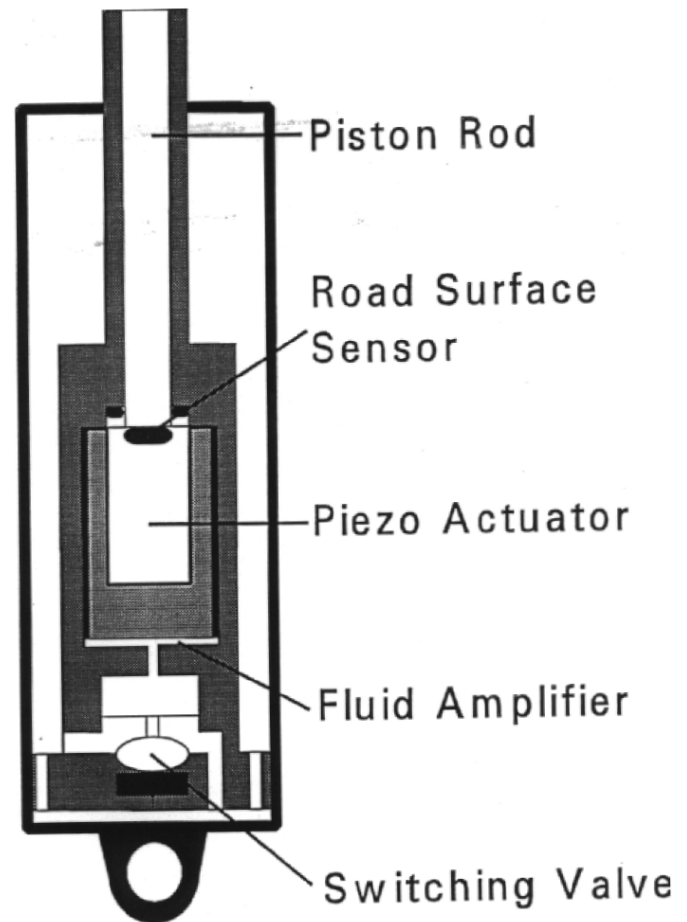

Schematic of a smart shock absorber

Smart Structures

Smart Structure Applications

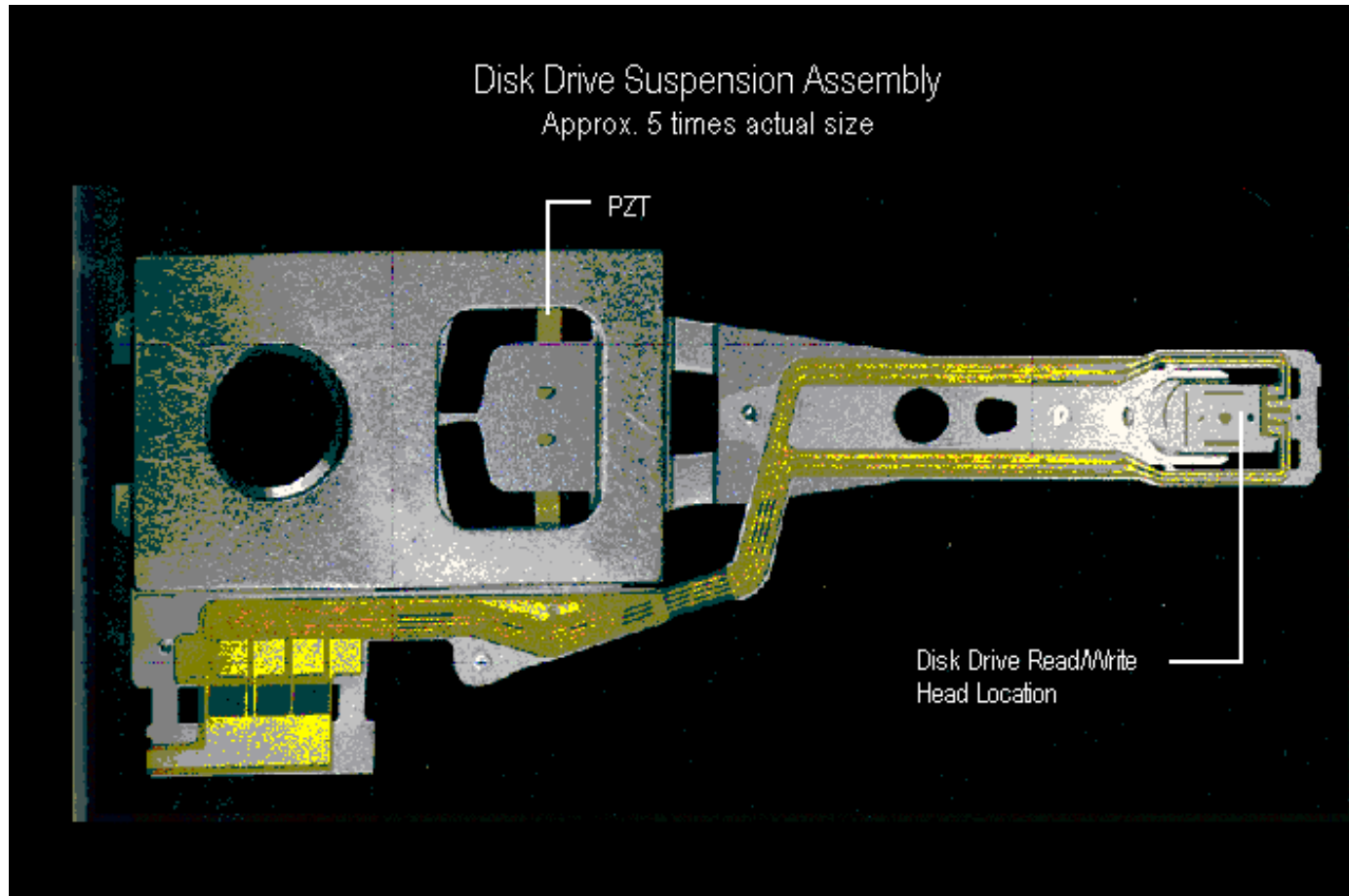

Sensor Technology Limited

Smart Structures

Smart Structure Applications

- Medical
 - Smart sensors (tele-medicine)
 - Micro robotics
 - Surgical tools
- Civil
 - Bridges
 - Earthquake protection

Smart Structures

Smart Structure Applications

Dowa Kasai Phoenix Tower Osaka, Japan

Stimuli of Interest

moderate earthquakes

strong winds

Adaptive Feature

HMD control system

Building Description

29 floors (AGL)

3 floors (BGL)

144.5 m height

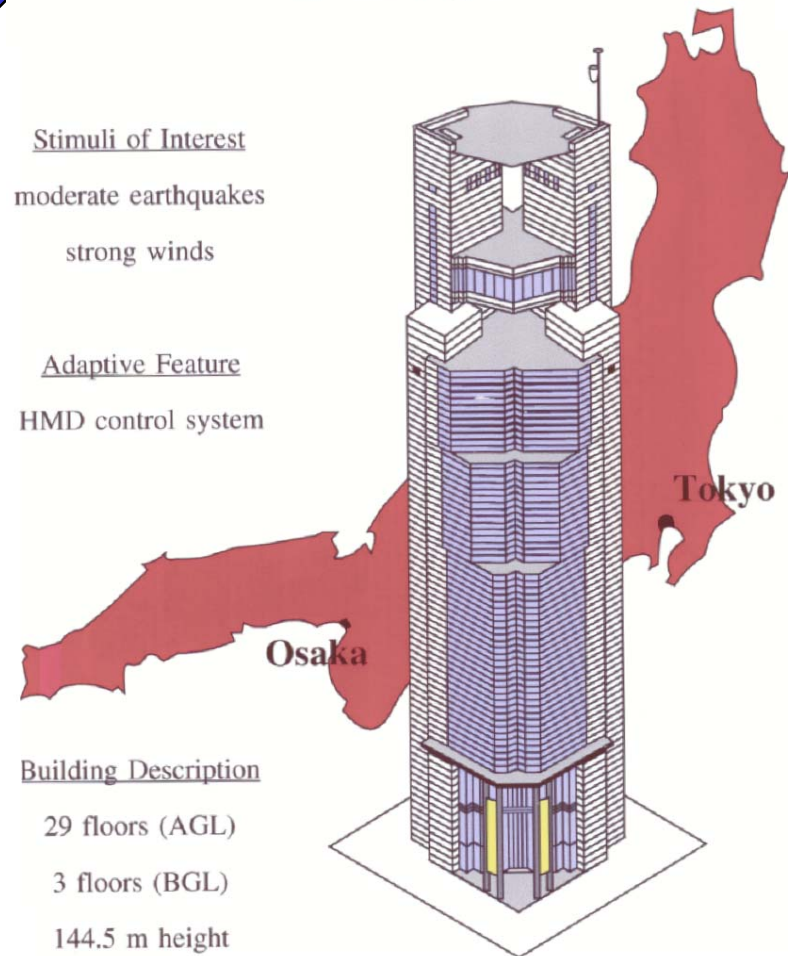

Smart Structures

Smart Structure Applications

Dowa Kasai Phoenix Tower Osaka, Japan

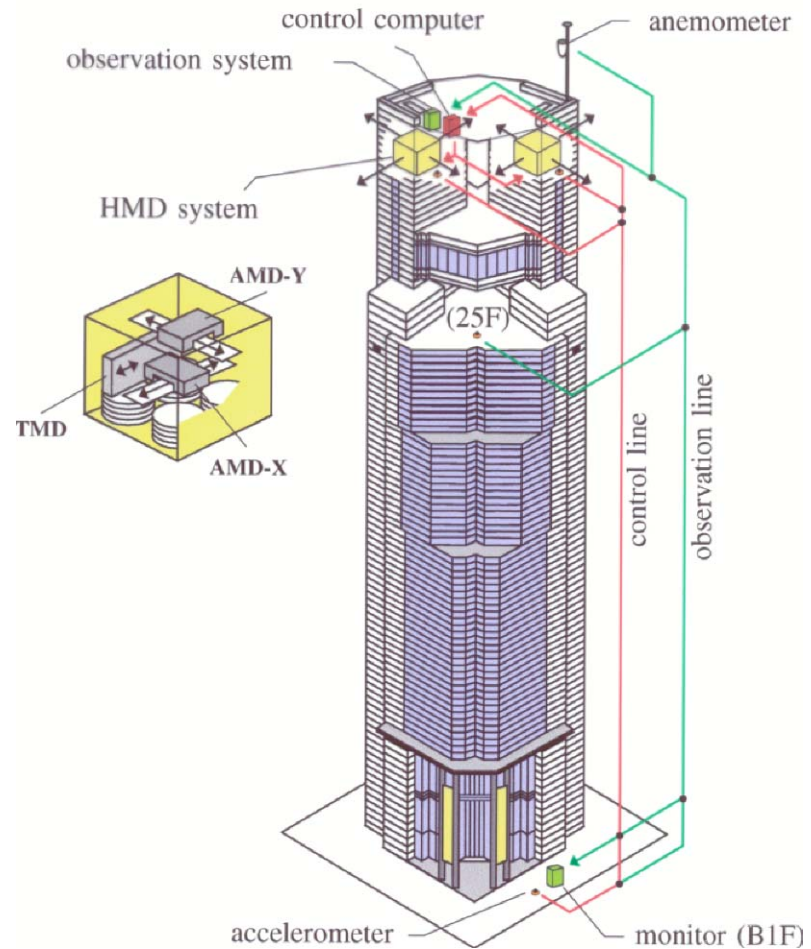

Smart Structures

Smart Structure Applications

Smart Bridges

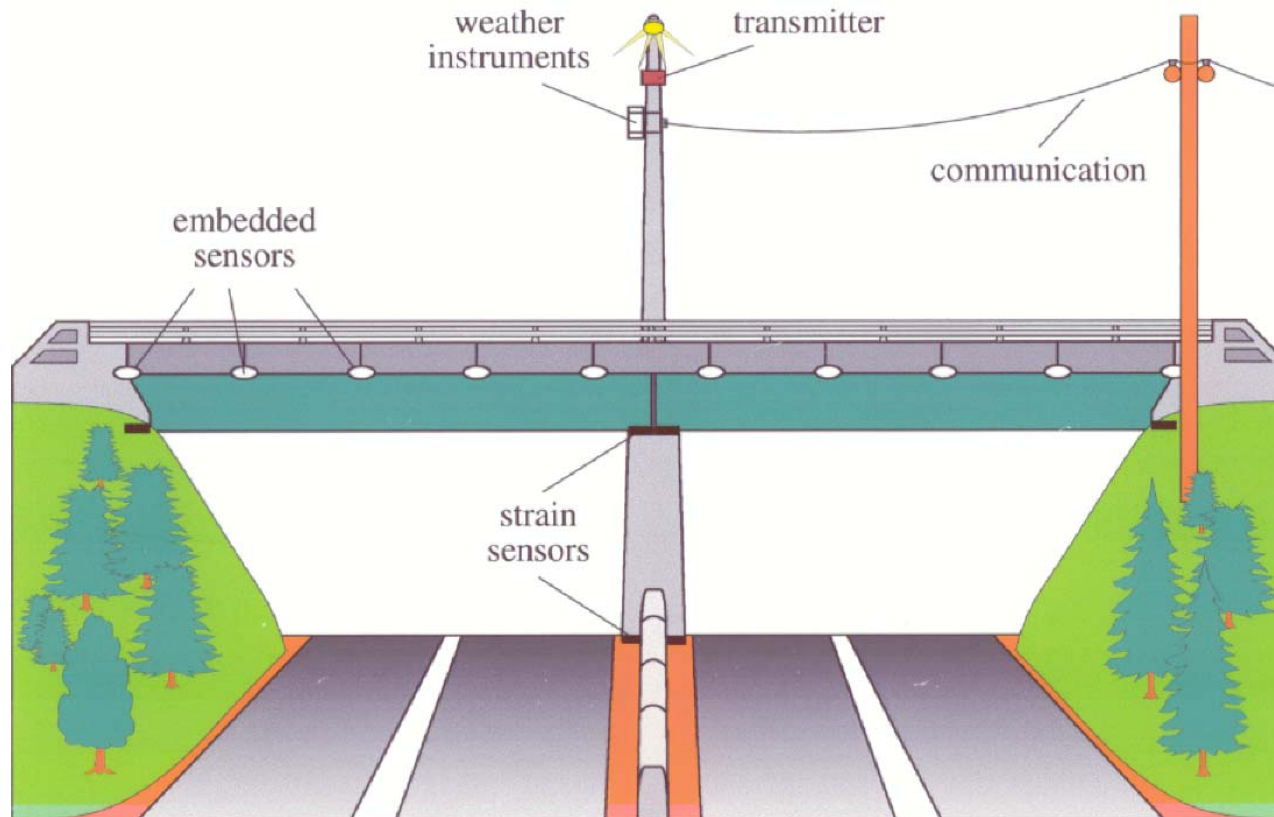

Smart Structures

Smart Structure Applications

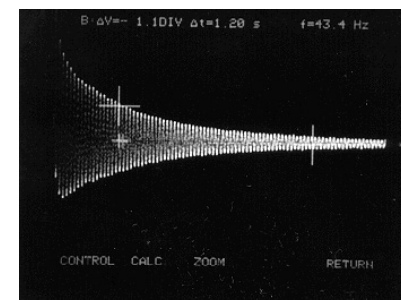
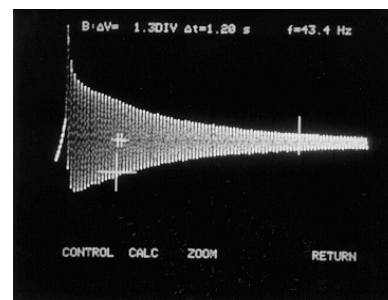
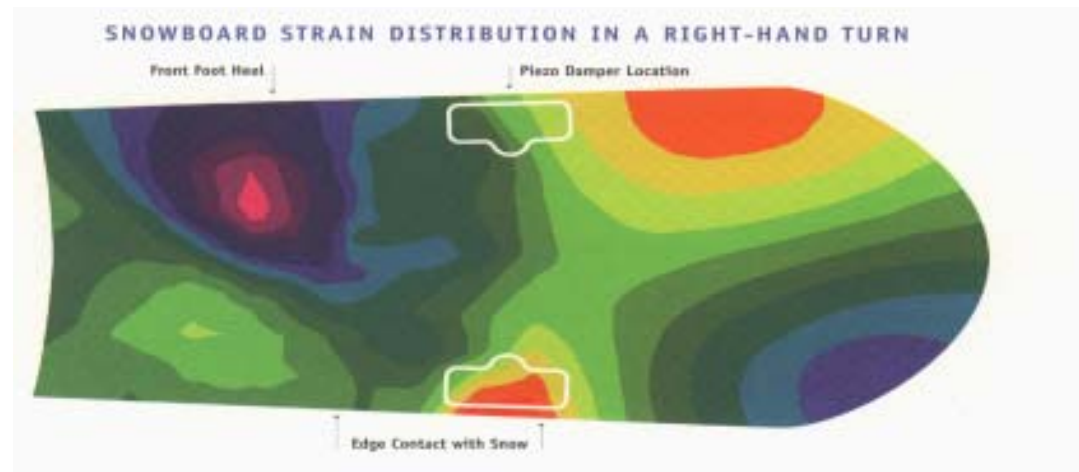

Sensor Technology Limited

Smart Structures

Smart Structure Research Programs



DARPA SMART PROGRAMS

Defense **A**dvanced **R**esearch **P**rojects **A**gency, DOD

Responsible to maintain US technological superiority over potential adversaries.

1. Sonar beam formation (transmit and receive).
2. Isolation of submarine wide aperture arrays from hull noise.
3. Medical systems based on ultrasonic or passive listening devices.
4. Wind tunnel test of a 1/6-scale F-18 shape adaptive wing at NASA.
5. Spin test of a subscale active helicopter blade.
6. Research on high-strain, high-force actuators for shape adaptive applications. This technology will be used for vortex wake reduction in submarines and other aerodynamic/hydrodynamic flow problems.

Sensor Technology Limited

Smart Structures

Smart Structure Research Programs



Required Smart Material Development Implementation

- Standard (ASTM) Method for Characterizing PZT Sub-Assemblies for Electrical, Mechanical, Thermal and Combined Load Strength/Fatigue Properties
- Experimental Database and Manufacturing Characteristics of Heterogeneous Structures for Reliable System Design
- Damage Models for Design of Embedded Sub-Assemblies which Account for Host Material Manufacturing Processes
- Better Quality PZT Materials, Especially Stacks
- New Materials Which Combine Attributes of PZT and SMA
- Robust Control Systems Which Adapt to Device Failures, Reduced Authority and Plant Changes
- Order of Magnitude Reduction in Size and Weight of Support Electronics



Smart Structures & Systems

MCDONNELL DOUGLAS

Sensor Technology Limited

Smart Structures

Smart Structure Research Programs



Actuator Materials Needs

Control Objective	Possible Actuators	Design Constraints	Materials and Issues
Cabin Noise	Tunable Reaction Mass Actuators	Light weight, reliable	Terfenol-D
	Structural Vibration Control	Co-location, impedance matching	Electroceramics with sufficient structural authority
	Panel Vibration Control	Co-location, impedance matching	Electroceramics with variable shape for impedance matching, embedded sensors
Helicopter Rotors	Tab actuators	High power, high g load, small space	High power, continuous duty electroceramic or Terfenol-D actuators
	Rotor twist (flexible root)	Torque limited, vibration dampers	High specific force actuators, ERFs or MRFs for damping
Variable Area Nacelle	Direct or Hydraulic	High hinge moments on flaps, small space, cost	Various approaches including SMAs, PZT or Terfenol-D hydraulics, smart composites
Surge control	Variable area bleed actuators	High case temperatures, high stroke-bandwidth	High temperatures - unclear whether active materials can survive. High temperature motors are a possibility
Clearance control	High temperature hydraulic actuators	Very high case temperatures	Strong need for high temperature actuators-possible high temp ferroelectric application
Fan Damping	PZT (active and passive)	High bending loads and strains	High stiffness actuators, high tensile strains in PZT, loss tangent

Sensor Technology Limited

Smart Structures

Smart Structure Research Programs

Noise and Vibration



de HAVILLAND

■ *The Noise and Vibration Sources*

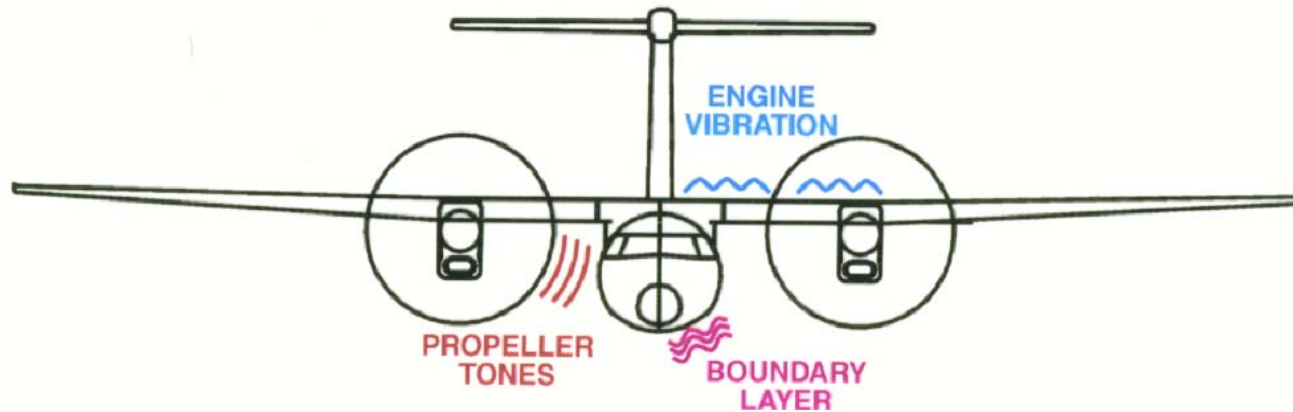

Sensor Technology Limited

Smart Structures

Smart Structure Research Programs

Noise and Vibration



de HAVILLAND

■ Active Noise and Vibration Suppression (ANVS) System

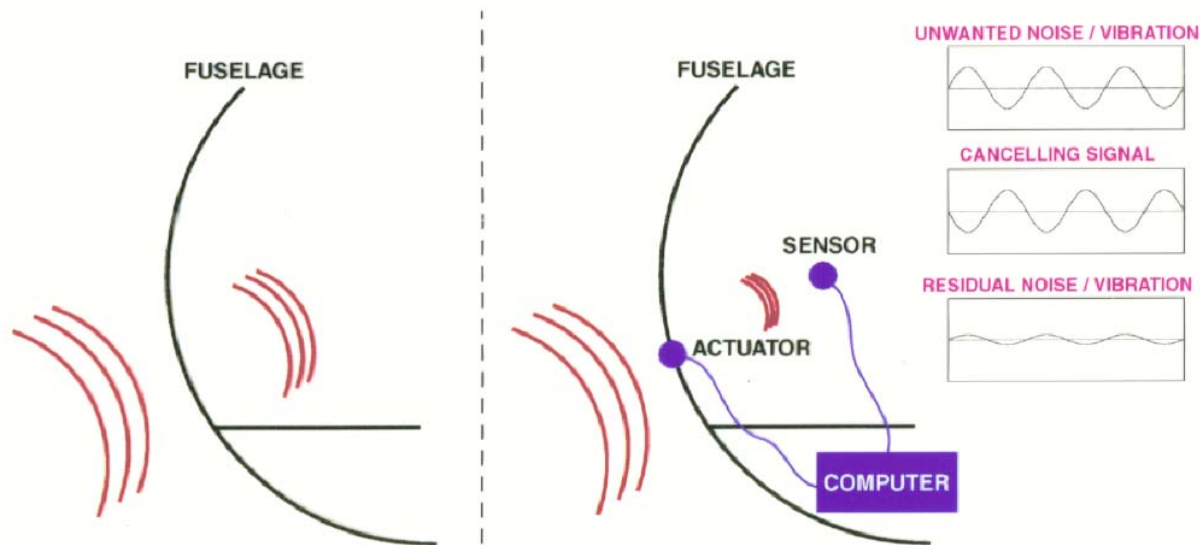

Sensor Technology Limited

- Antennas
 - lightweight and deployable antennas required
 - sufficient aperture area and accuracy required in order to accomplish mission goals
 - communication antenna and reflector performance require phased arrays for wide parabolic dishes which can maintain their shape to a high degree of accuracy

Smart Structures

Typical Applications for Space Technology

- Space-based radar and antennas
 - truss structures are susceptible to complex modes of vibration in the absence of gravity
 - rapid damping of transient disturbances which induce structural vibrations needed to maintain stability
 - quasi-static disturbances which produce deformations in the structure must be corrected for the optimal performance of the structure to be realized

Smart Structures

Antenna requirements

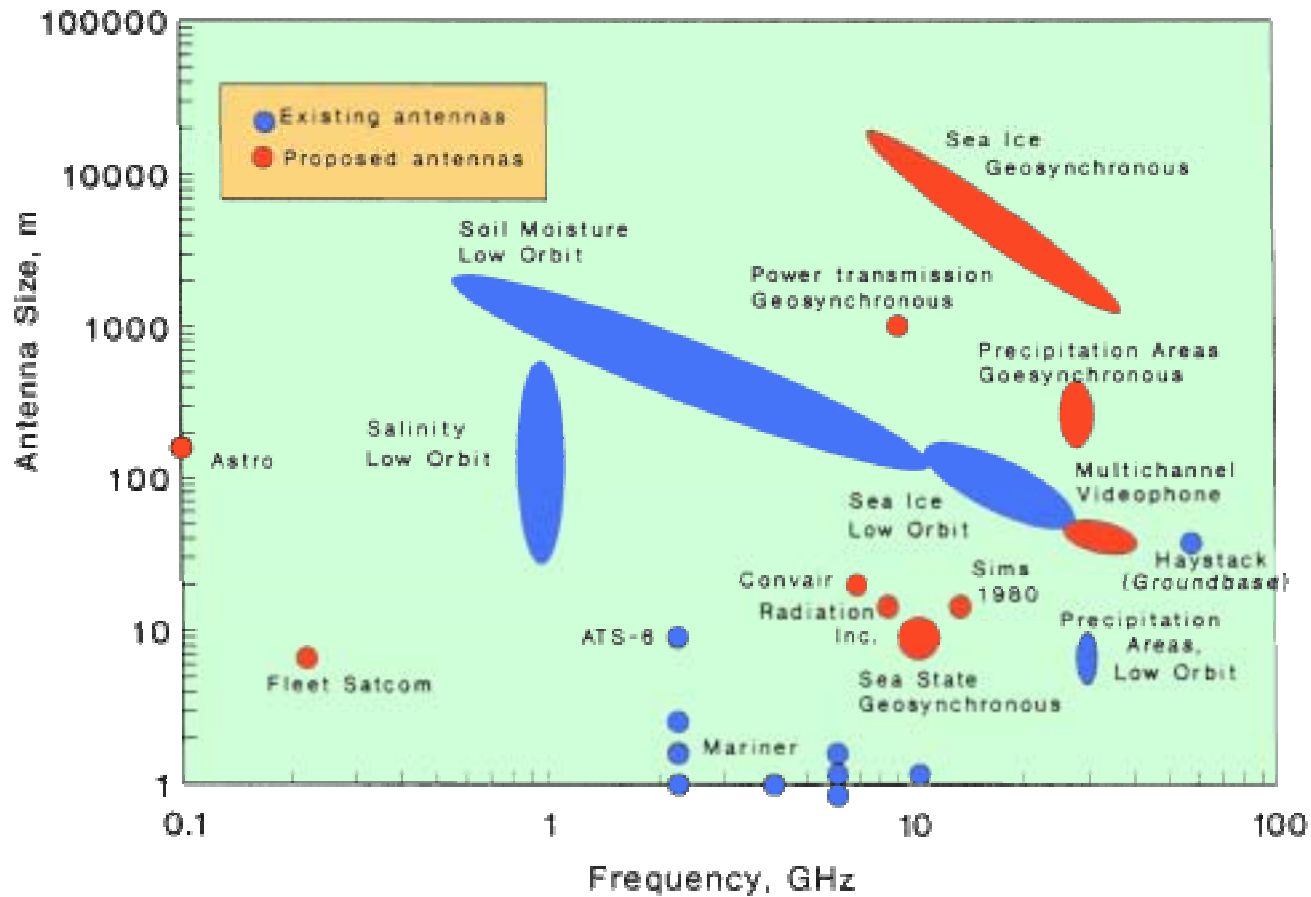

Sensor Technology Limited

Smart Structures

Relevance of Technology to Space Applications

- Active vibration control in trusses, booms and antennas
 - lack of rigidity in structures, large dimensions and absence of gravity
- Active shape control of large, flexible structures and antennas
 - thermal cycling, structural loading and environmental stresses
- Health monitoring
 - damage control and diagnostics from impact, creep, fatigue in structures

Sensor Technology Limited

Smart Structures

Space Environment Effects

- Vacuum
 - Solar UV degradation, Contamination
- Neutral
 - Mechanical effects
 - Aerodynamic drag, Physical sputtering
 - Chemical effects
 - Atomic oxygen attack, Spacecraft glow
- Micrometeoroid/Orbital debris
 - Hypervelocity impacts

Space Environment Effects

- Plasma
 - Spacecraft charging
 - Shift in ground potential
 - Electrostatic discharging
 - Dielectric breakdown
 - Gaseous arc discharge
 - Enhanced sputtering
 - re-attraction of contamination
- Radiation
 - Total dose effects
 - Solar cell degradation
 - Sensor degradation
 - Electronics degradation
 - Single event effects
 - Upsets, latchup, etc.

Smart Structures

Components of a Smart Structure

The most basic definition of a smart structure involves the sensing of an environmental change and a response to that change. Usually this process utilizes electronic processing. In order to carry out these activities, a smart structure must have the following components:

Sensors, actuators and control systems

Smart Structures

Components of a Smart Structure

- Sensor(s)
 - To monitor environmental changes and generate signals proportional to the changing measurand

Smart Structures

Components of a Smart Structure

- Actuator(s)
 - The actuators are used to change the properties of the smart structure in order to achieve the desired response

Smart Structures

Components of a Smart Structure

- Control Systems(s)
 - The control system continually monitors the sensor's signal, processing the information in order to determine if action is required. If an action is required, then a signal is applied to the appropriate actuator(s).

Smart Structures

Components of a Smart Structure

- Sensor(s)
 - To monitor environmental changes and generate signals proportional to the changing measurand
- Actuator(s)
 - The actuators are used to change the properties of the smart structure in order to achieve the desired response
- Control Systems(s)
 - The control system continually monitors the sensor's signal, processing the information in order to determine if action is required. If an action is required, then a signal is applied to the appropriate actuator(s).

Smart Structures

System Component Schematic

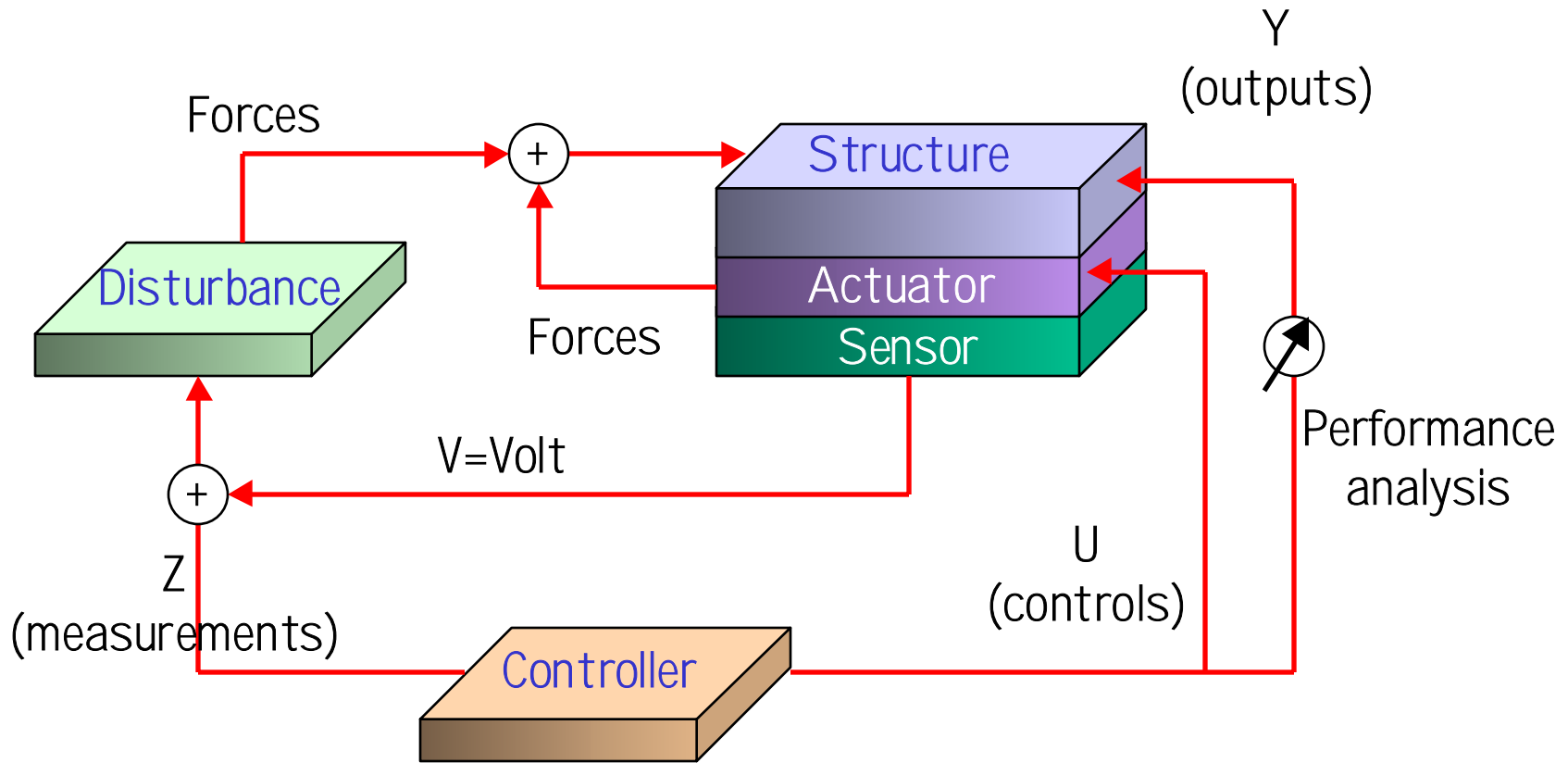

Smart Structures

Actuator Considerations

A number of different actuators can be incorporated into a smart structure in order to generate the appropriate response to a detected environmental variation. The type of actuator is dependent on a number of parameters.

Smart Structures

Actuator Considerations

- Nature of the actuation
 - Optical, magnetic, thermal, mechanical, chemical, etc.
- Nature of driving energy
 - Thermal, magnetic, electrical, chemical, etc.
- Environmental considerations
 - Corrosion, thermal, magnetic, electrical, etc.

Smart Structures

Actuator Considerations

- Interfacing
 - Size, geometry, mechanical properties, etc.
- Properties of the actuator
 - Displacement, force generation, hysteresis, response time, bandwidth, etc.

Smart Structures

Sensor Considerations

A number of different sensors can be incorporated into a smart structure to measure a number of different environmental variations. The type of sensor utilized in smart structures is dependent on a number of factors.

Smart Structures

Sensor Considerations

- Nature of measurand
 - Radiation, magnetic, thermal, mechanical, chemical, etc.
- Sensor output
 - Thermal, magnetic, electrical, optical, mechanical, etc.
- Environment
 - Corrosive, thermal, magnetic, electrical, etc.

Smart Structures

Sensor Considerations

- Interfacing
 - Size, geometry, mechanical properties, etc.
- Operational properties
 - Sensitivity, bandwidth, linearity, gauge length, operational range, etc.

Smart Structures

Smart Control System

- The Smart Control System will provide feedback control for the sensors and actuators.
- The SCS will include the interfaces necessary for the operation of the sub-system modules

Smart Structures

Smart Control System

- The SCS will consist of the following:
 - Analogue-to-digital and digital-to-analogue converters
 - Input signal amplification and filtering
 - Control algorithm
 - Digital signal processor (DSP)
 - Output power supply

Smart Structures

System Component Schematic

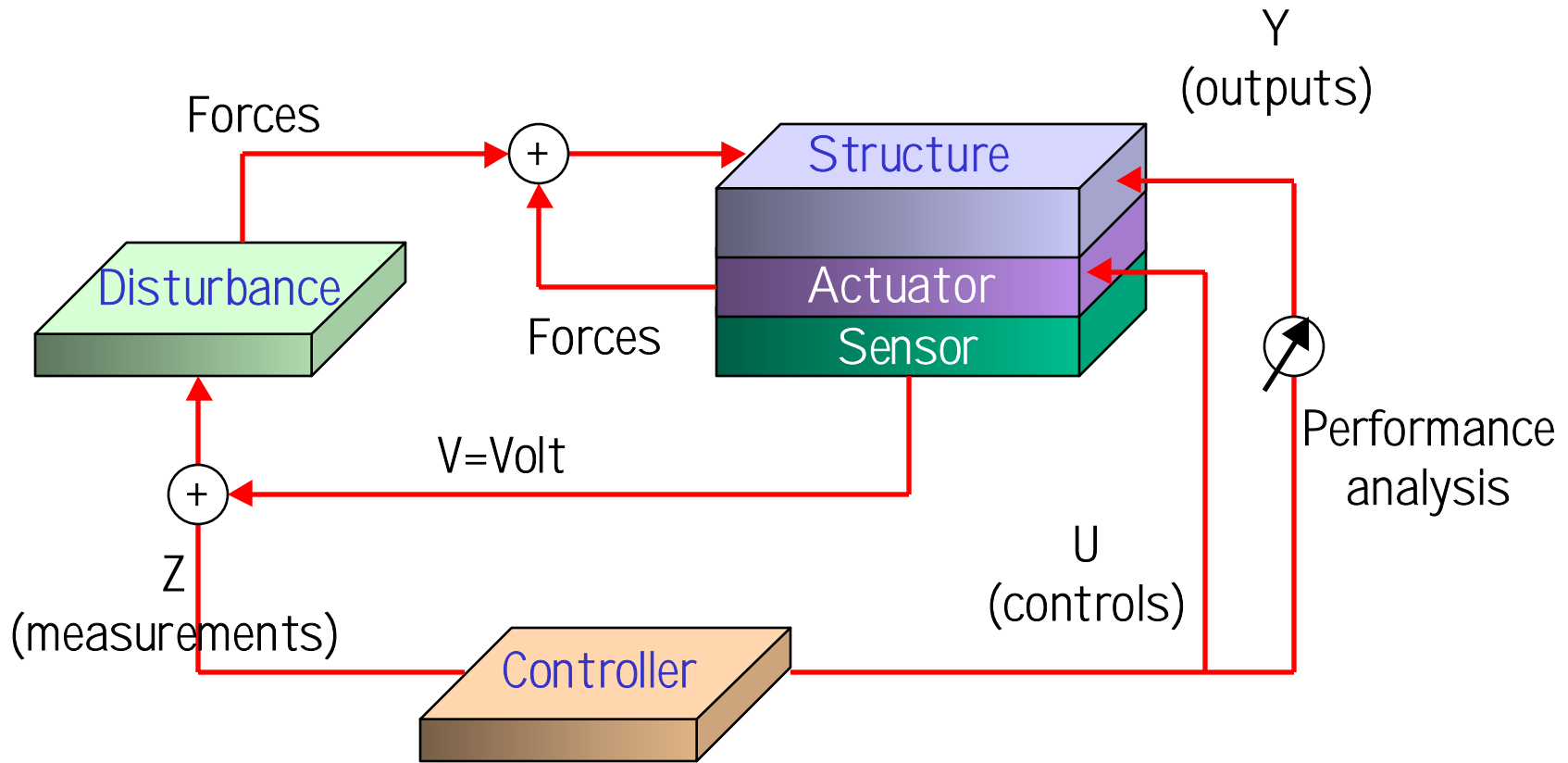

Smart Structures

Functional Flow Diagram

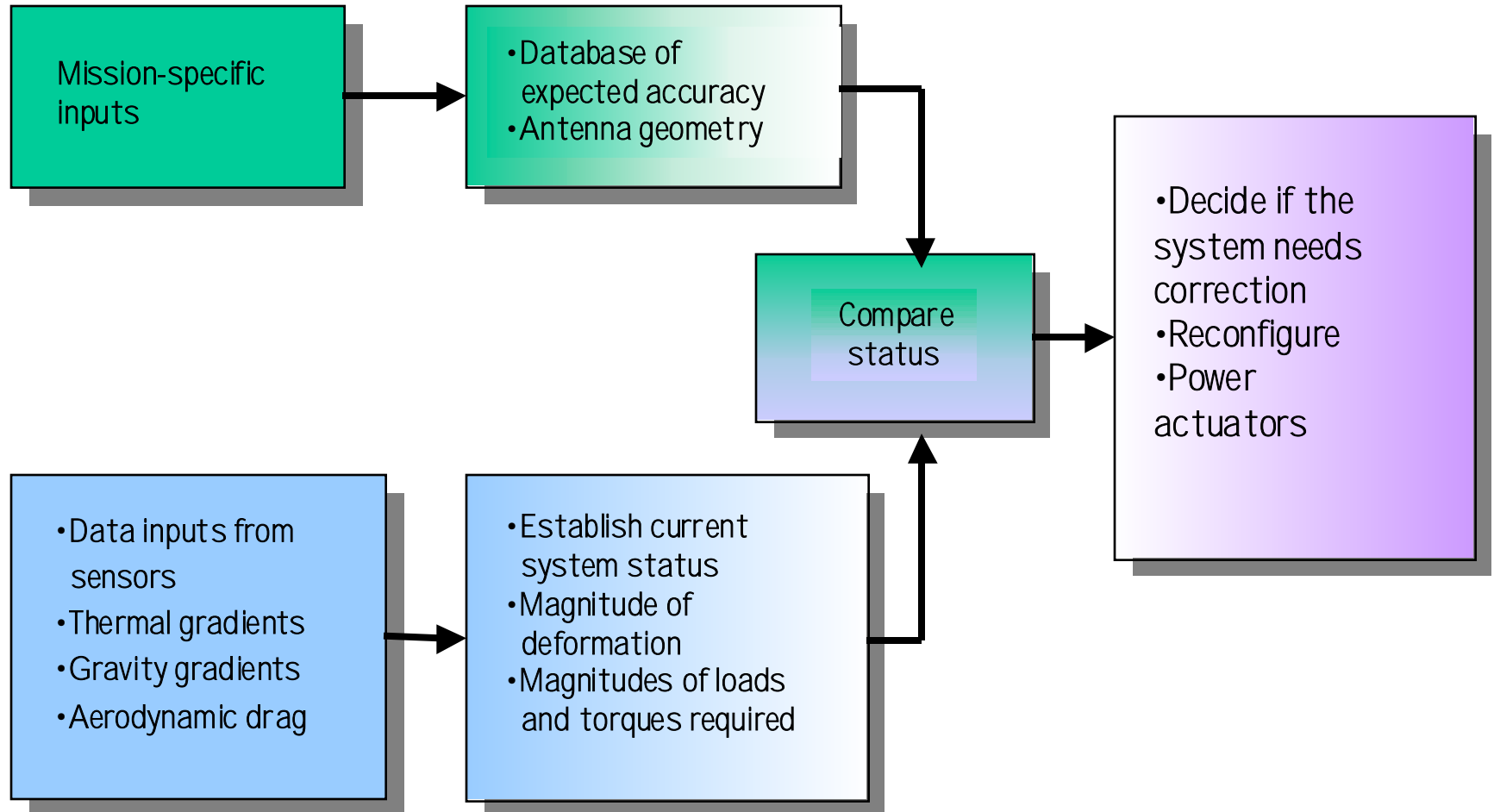

Smart Structures

Conclusions

- The current 'state-of-the-art' with respect to smart structures has been established.
- The space relevance of these technologies has been presented.

Conclusions

- The main applications emerging are:
 - Active Vibration Control (AVC)
 - Active Noise Control (ANC)
 - Active Shape Control (ASC)
 - Active Health Monitoring (AHM)

Smart Structures

Conclusions



SMART SYSTEMS EXPERTISE

Systems Engineering

control systems technology

Materials Science

sensor/structure compatibility

Applied Physics

acoustics, optics transducers

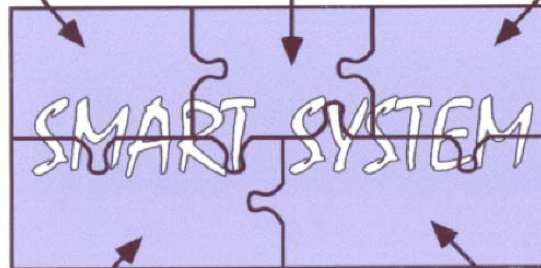

microelectronics algorithms

Electrical Engineering

sensor/structure integration

Mechanical Engineering

Sensor Technology Limited

Application Sectors for Smart Structure Sub-Systems

SECTOR	APPLICATION	BENEFIT	Smart Structure Utilization		
			ASM	ASP	SCS
Aerospace	Health Monitoring Vibration Control Shape Control	Damage Detection Life Cycle Management Fuel Savings	●	● ● ●	● ●
Defence	Shape Control Vibration Control Health Monitoring	Firing Accuracy of Weapons Fuel Savings through Adaptive Wings, Rockets and Missiles Quieter Submarines and Ships Life Cycle Management Early Detection of Damage	● ●	● ● ● ●	● ● ●
Automotive	Noise Control Vibration Control Health Monitoring	Passenger Comfort (Cabin) Engine Life Cycle Management Damage Detection (Early Warning)	●	● ●	● ●

Application Sectors for Smart Structure Sub-Systems

SECTOR	APPLICATION	BENEFIT	Smart Structure Utilization		
			ASM	ASP	SCS
Industrial	Vibration Control	Machine Tool Chatter Control Foundation Isolation Operator Comfort in Heavy Machinery	● ● ●		● ● ●
	Noise Control	Airconditioning, Ventilation Exhaust Systems		● ●	● ●
Medical	Health Monitoring	Early Warning Systems (Preventive-medicine)		●	
	Shape Control	Surgical Micro-Robots Surgical Tools	●	●	● ●
Civil	Vibration Control	Protection of Bridges Earthquake Protection	● ●		● ●
	Health Monitoring	Bridges		●	

Smart Structures

Conclusions

- Characteristics of Smart Materials
 - Other materials
 - Piezoelectrics