

Roket yanma odası modları

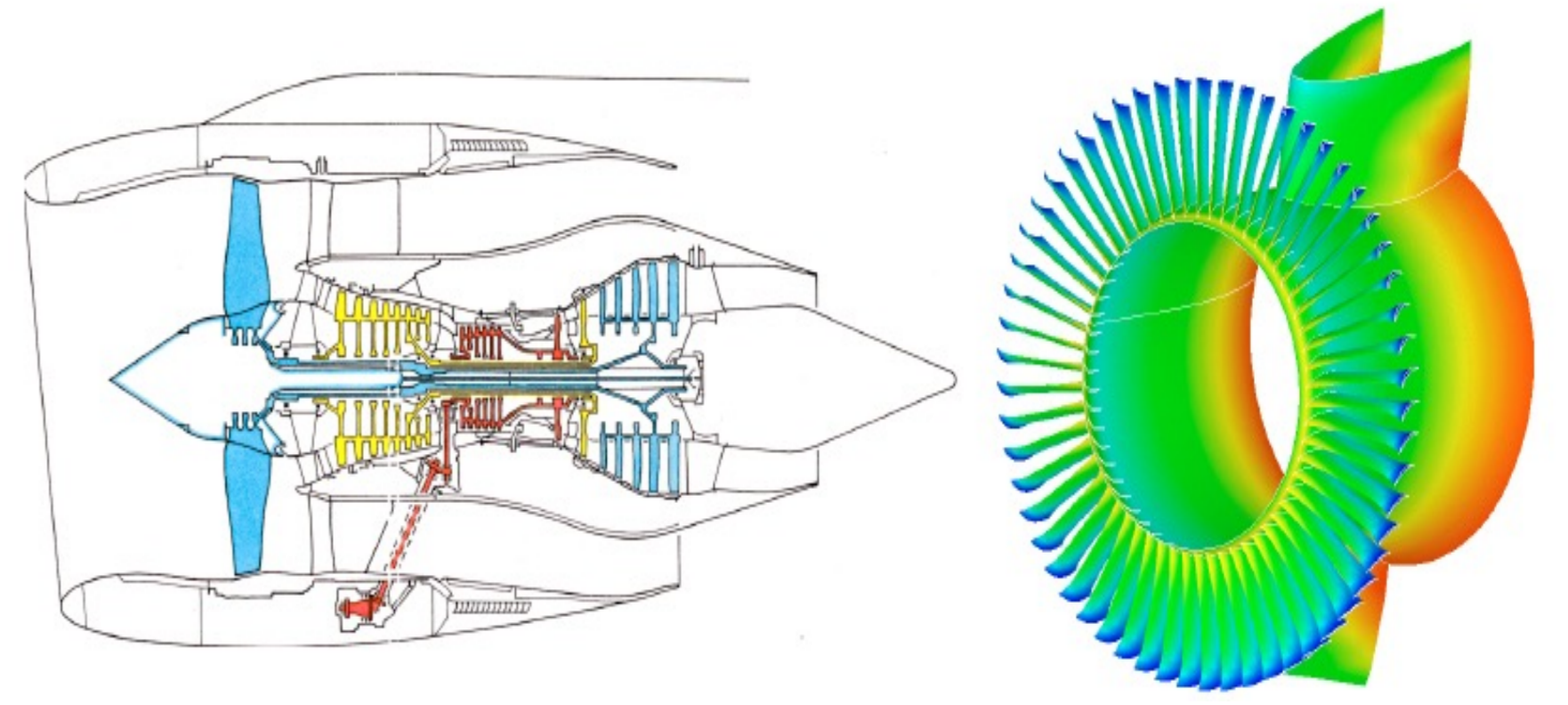

Kompresör tasarım ve optimizasyon analizleri

İtki sistemleri:

- Newton'un 3. yasasının (Etki-tepki yasası) uygulanması
- Hava araçlarında sürtünmeyi yenen ve ileri gitmeyi sağlayan kuvvetin oluşturulması

Çalışılan bazı konular:

- Roketlerde itki
- Süpersonik yanmalı motorlar
- Yakıt tüketimi optimizasyonu



TEİ-TJ300 Turbojet motoru

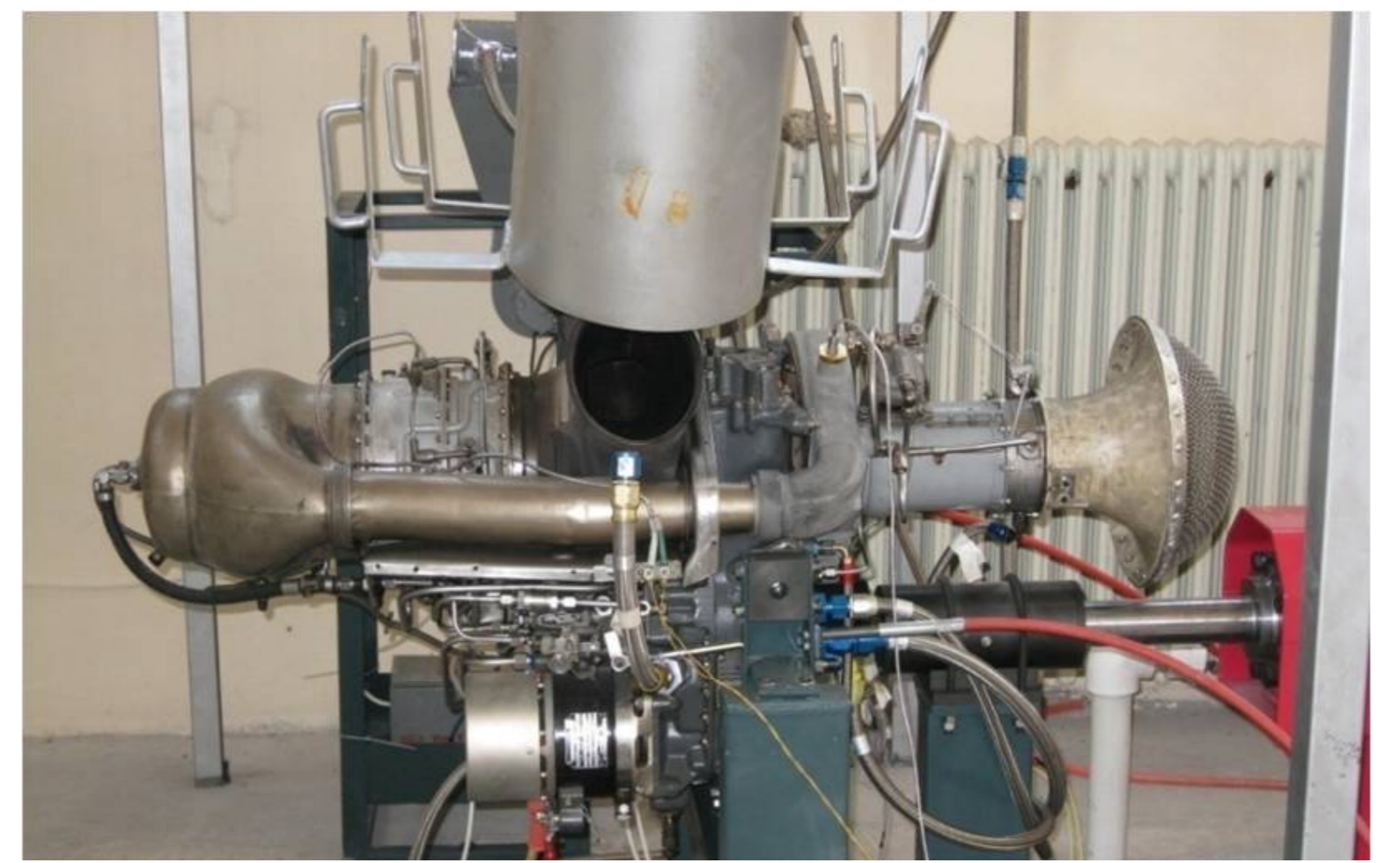

TEİ-TS1400 Turboşaft motoru

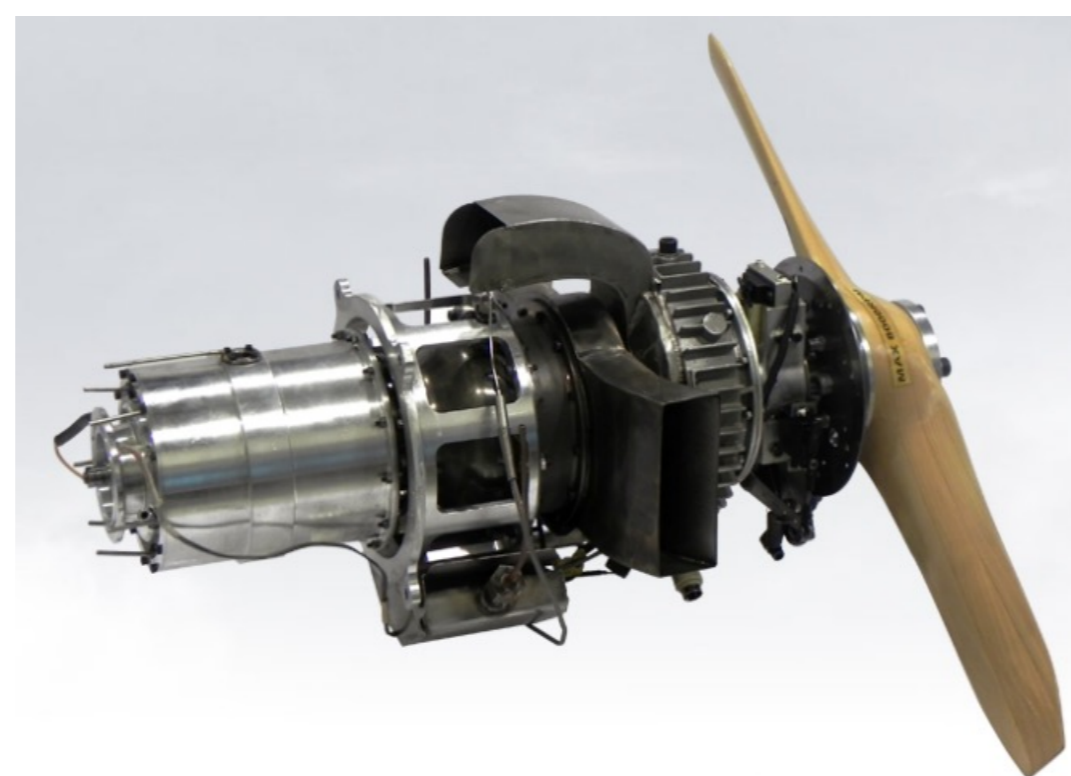

TEİ-TP38 Turboprop motoru

